

LLRF2017, Barcelona

**A prototype system of multiharmonic
vector voltage control for the J-PARC
rapid cycling synchrotron**

Fumihiko Tamura

J-PARC center

October 2017

Contents

1. Introduction
2. Multiharmonic vector voltage control system prototype
3. Commissioning
4. Beam test results
5. Summary and outlook

J-PARC rapid cycling synchrotron (RCS)

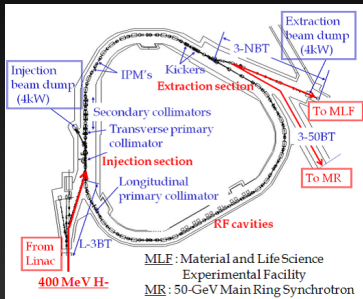

parameter	
circumference	348.333 m
energy	0.400-3 GeV
beam intensity	(achieved) 8.3×10^{13} ppp
repetition freq	25 Hz
accelerating frequency	1.22-1.67 MHz
harmonic number	2
maximum rf voltage	440 kV
No. of cavities	12
Q-value of rf cavity	2

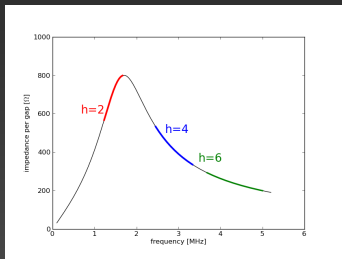

- **Magnetic alloy (MA) cavities employed**
 - High rf voltage, 440 kV by 12 cavities
- **Wideband (Q = 2): no tuning, dual harmonic operation**
 - Bunch shaping using second harmonic rf indispensable for high intensity operation
- **Wake is multiharmonic;**
 multiharmonic beam loading
 compensation necessary

J-PARC uses rf feedforward method so far. It works fairly well. (Cf. my PRST-AB papers, presentation at LLRF13)

J-PARC rapid cycling synchrotron (RCS)

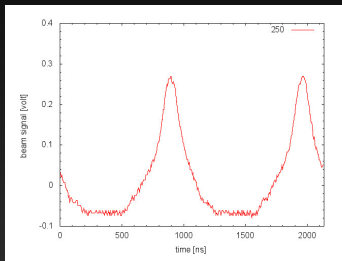

Fundamental accelerating rf only

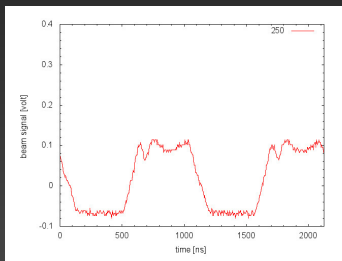

With second harmonic

parameter	
circumference	348.333 m
energy	0.400-3 GeV
beam intensity	(achieved) 8.3×10^{13} ppp
repetition freq	25 Hz
accelerating frequency	1.22-1.67 MHz
harmonic number	2
maximum rf voltage	440 kV
No. of cavities	12
Q-value of rf cavity	2

- **Magnetic alloy (MA) cavities employed**
 - High rf voltage, 440 kV by 12 cavities
- **Wideband (Q = 2): no tuning, dual harmonic operation**
 - Bunch shaping using second harmonic rf indispensable for high intensity operation
- **Wake is multiharmonic;**
multiharmonic beam loading
compensation necessary

J-PARC uses rf feedforward method so far. It works fairly well. (Cf. my PRST-AB papers, presentation at LLRF13)

J-PARC rapid cycling synchrotron (RCS)

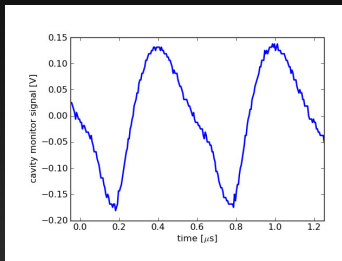

Measured wake voltage waveform

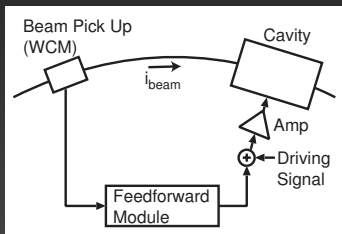

Rf feedforward method

parameter	
circumference	348.333 m
energy	0.400-3 GeV
beam intensity	(achieved) 8.3×10^{13} ppp
repetition freq	25 Hz
accelerating frequency	1.22-1.67 MHz
harmonic number	2
maximum rf voltage	440 kV
No. of cavities	12
Q-value of rf cavity	2

- **Magnetic alloy (MA) cavities employed**
 - High rf voltage, 440 kV by 12 cavities
- **Wideband (Q = 2): no tuning, dual harmonic operation**
 - Bunch shaping using second harmonic rf indispensable for high intensity operation
- **Wake is multiharmonic; multiharmonic beam loading compensation necessary**

J-PARC uses rf feedforward method so far. It works fairly well. (Cf. my PRST-AB papers, presentation at LLRF13)

Why feedback is considered?

Feedforward is open loop, compensation signal is generated from beam signal.

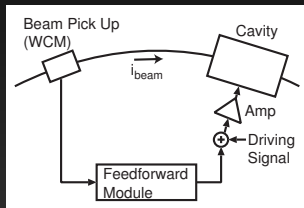

What we learned from high power (> 800 kW) beam tests:

- Tube amplifier gain changes with output current. Optimum parameters of FF different for various beam conditions
- Waveform distortion increases with high output current of tubes under heavy beam loading
 - FF cannot compensate this by definition

Therefore, we consider to employ multiharmonic vector voltage FB:

- FB should work with gain variation, if variation is within the margin
- Voltage waveform distortion is to be compensated

A vector voltage control system prototype for one cavity developed in FY2016.

Why feedback is considered?

Feedforward is open loop, compensation signal is generated from beam signal.

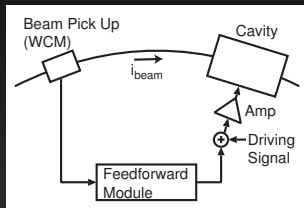

What we learned from high power (> 800 kW) beam tests:

- Tube amplifier gain changes with output current. Optimum parameters of FF different for various beam conditions
- Waveform distortion increases with high output current of tubes under heavy beam loading
 - FF cannot compensate this by definition

Therefore, we consider to employ multiharmonic vector voltage FB:

- FB should work with gain variation, if variation is within the margin
- Voltage waveform distortion is to be compensated

A vector voltage control system prototype for one cavity developed in FY2016.

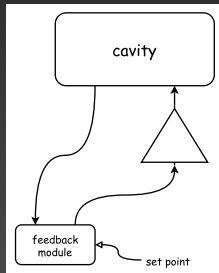

1. Introduction

2. Multiharmonic vector voltage control system prototype

3. Commissioning

4. Beam test results

5. Summary and outlook

Multiharmonic vector voltage control system prototype



- Constructed by Mitsubishi Electric Tokki Systems
- μ TCA.4 based
 - 1 AMC + 1 RTM
 - 8 ADC and 2 DAC
 - Main I/Os on rear side
- Xilinx Zynq FPGA, EPICS IOC running on embedded linux
- Setting / monitoring via EPICS CA
- EPICS I/Q waveform monitor
 - 4096 pts/ch, up to 144 Msps

Block diagram

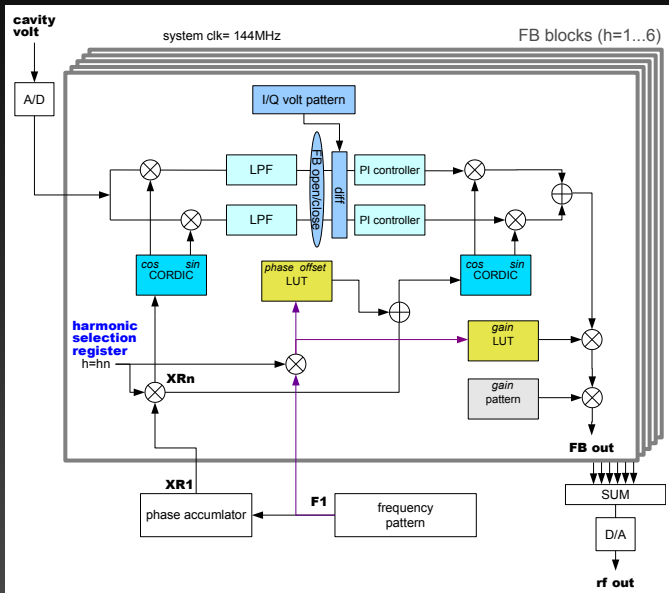

Input: gap voltage monitor, output: multiharmonic rf signal
 six FB blocks, 144 MHz clock

Block diagram

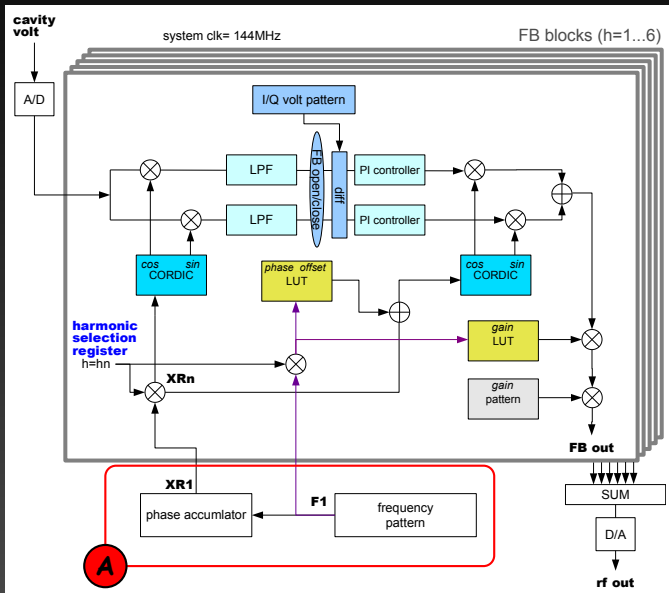

A: revolution freq pattern f1 and phase accumulator.
 Generates phase signal XR1 ($-\pi$ to π)

Block diagram

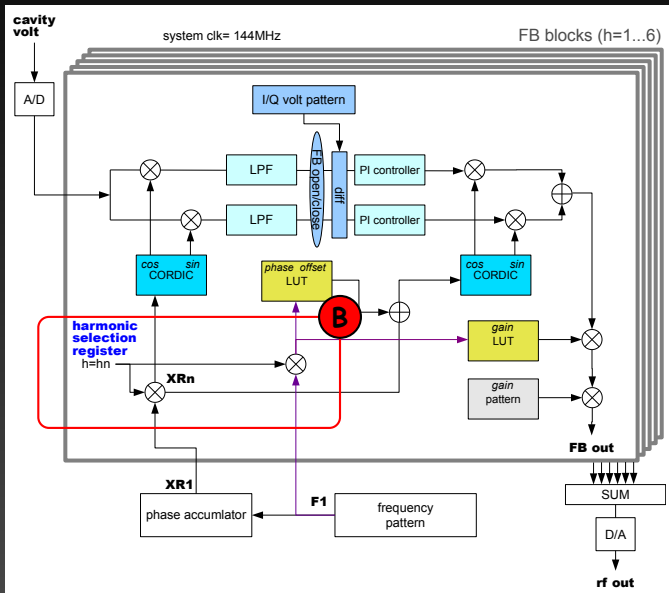

B: XR_n and f_n generated by multiplying XR_1 and f_1 with harmonic number h_n
 Used for I/Q demod/mod and addressing of LUT. LUTs are necessary for f sweep

Block diagram

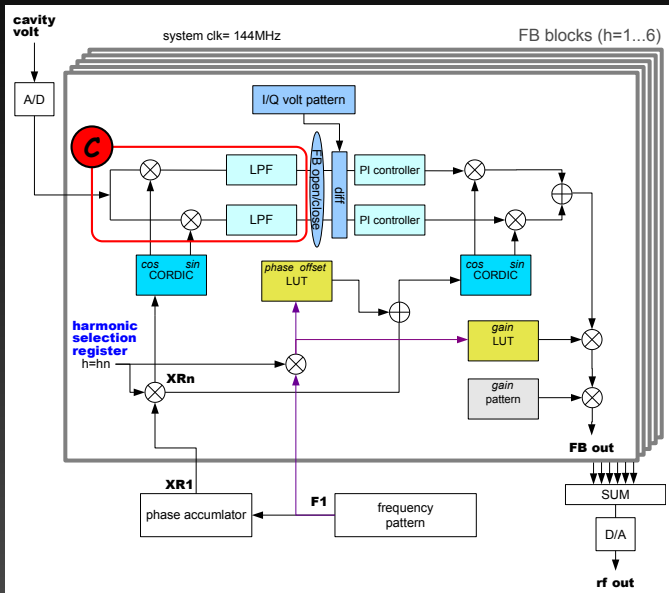

C: Complex amplitude obtained by I/Q demodulation

Block diagram

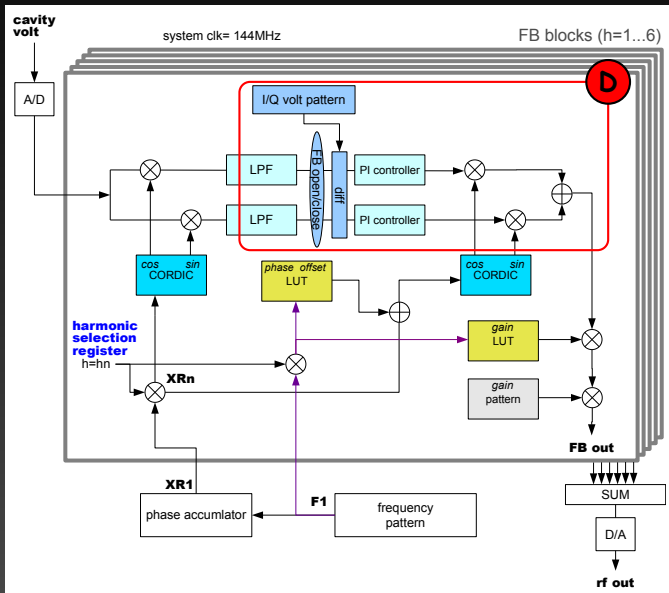

D: I/Q voltage pattern, rf signal is generated via PI control and I/Q modulation
 FB open/close is for commissioning

Block diagram

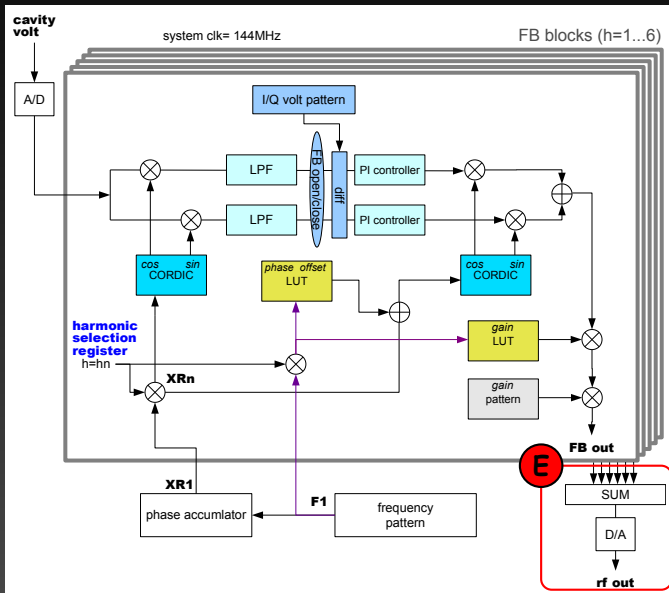

E: multiharmonic rf signal obtained by summing up the signals from blocks

phase offset LUT and gain LUT

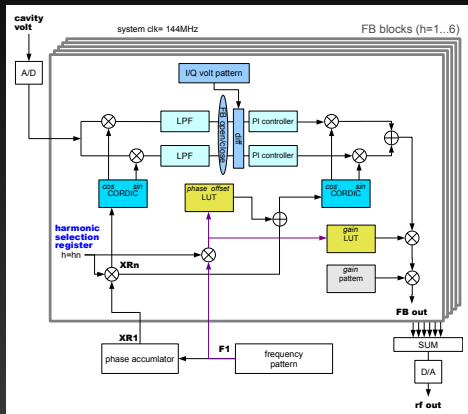

LUTs implemented for various frequencies (freq sweep and multiharmonics).
fn used as address.

Phase offset LUT:

- Phase offset between I/Q demod and mod, to control phase transfer function of the block
- Most important LUT

Gain LUT:

- h1 min freq 600 kHz, h6 max 5.1 MHz, cavity impedance several times different
- adjust overall gain by this LUT

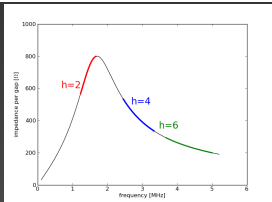

LUT setting is the key for commissioning of the system.

phase offset LUT and gain LUT

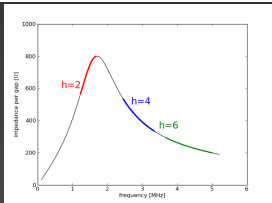
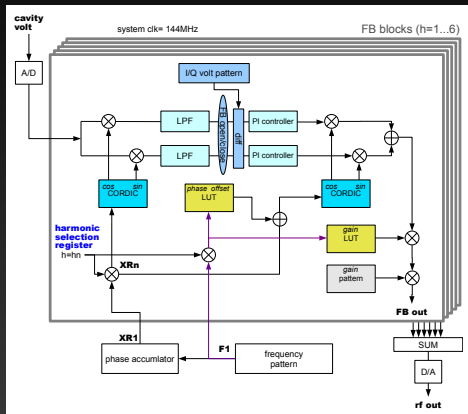

LUTs implemented for various frequencies (freq sweep and multiharmonics).
fn used as address.

Phase offset LUT:

- Phase offset between I/Q demod and mod, to control phase transfer function of the block
- Most important LUT

Gain LUT:

- h1 min freq 600 kHz, h6 max 5.1 MHz, cavity impedance several times different
- adjust overall gain by this LUT

LUT setting is the key for commissioning of the system.

1. Introduction

2. Multiharmonic vector voltage control system prototype

3. Commissioning

4. Beam test results

5. Summary and outlook

Setup for off-beam commissioning

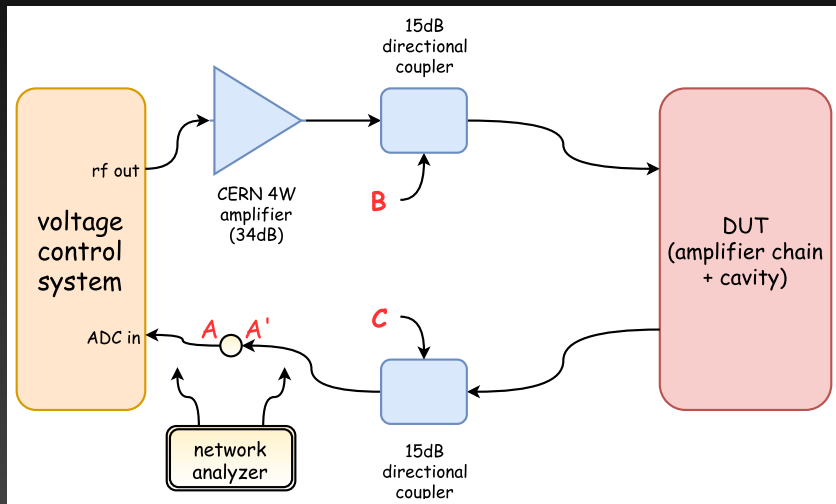

Measurement setup for commissioning of the vector voltage control system.

Commissioned by using EPICS I/Q monitor and network analyzer.

Phase offset LUT setting

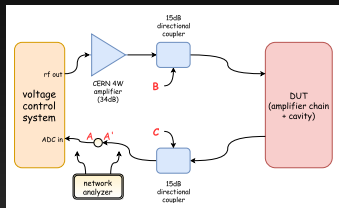

- set point: $(I, Q) = (5000, 0)$
- FB open
- phase offset LUT: "0" const
- f sweep: 0.4-8.99 MHz, 200 points
- I/Q data interpolated

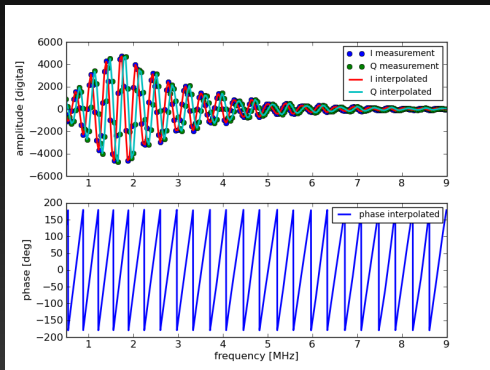

- **I/Q values oscillate** → system has frequency response of **phase**
 - almost linear, due to delays (cable and digital)
- Amplitude response corresponds to cavity frequency response
- **Phase offset LUT is set by using measured response**

Phase offset LUT setting

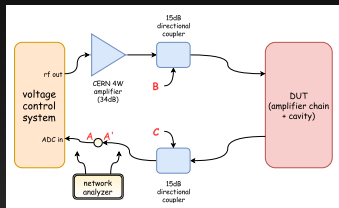

- set point: $(I, Q) = (5000, 0)$
- FB open
- phase offset LUT set
- f sweep: 0.4-8.99 MHz, 200 points
- I/Q data interpolated

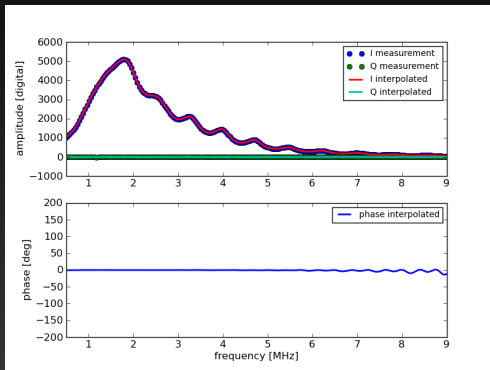

- **Phase response is compensated by LUT**
 - Throw I \rightarrow receive I, condition to close FB
 - Small errors observed in high freq region, because of small amplitudes
- h6 freq: 3.6-5.1 MHz, we want keep FB gain in the region \rightarrow need to set gain LUT

Gain LUT setting

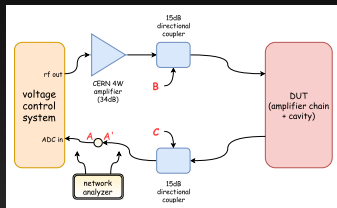

- set point: $(I, Q) = (1000, 0)$
- FB open
- phase offset LUT set
- gain LUT constant / set
- f sweep: 0.4-8.99 MHz, 200 points
- I/Q data interpolated
- From measurement with gain LUT constant, gain LUT is set so that amplitude ($\sqrt{I^2 + Q^2}$) is constant
 - we limit max gain to $\times 10$
- Need iteration due to amplitude dependence of tube amp. Flat gain up to 5.5 MHz obtained by second setting
 - for higher frequencies, $\times 10$ is not enough, decay seen
- With gain LUT, system gain is adjusted for target freq range

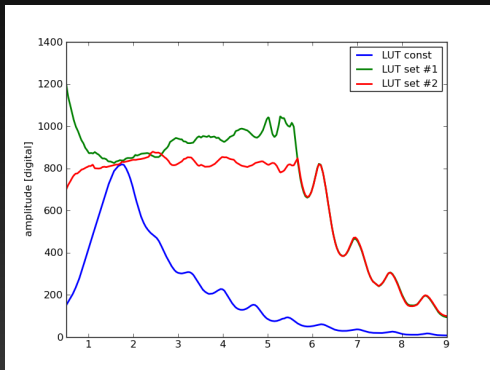

Open loop gain

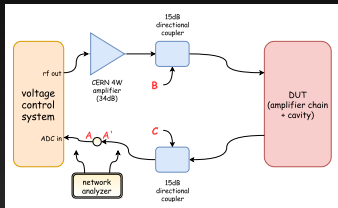

- set point: $(I, Q) = (0, 0)$
- FB closed
- phase offset LUT set
- gain LUT constant / set
- S_{21} from A to A' measured by NA
- **h1-h6 blocks used**, $f_{rf(h2)} = 1.2$ MHz, S_{21} (A to A') is measured by network analyzer
 - Gain LUT constant: gain is different for each harmonic
 - Gain LUT set: similar response for all harmonics
- Phase is near 180 deg at the centers of harmonics
 - condition to close FB

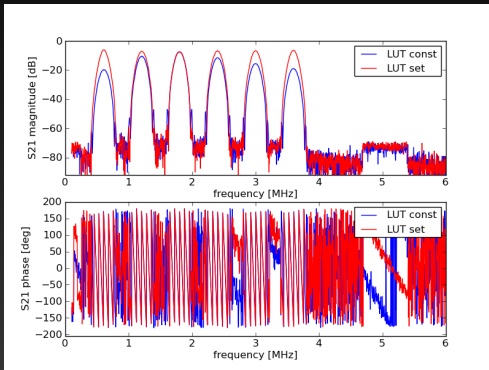

Now, we are ready to close the feedback.

Open loop gain

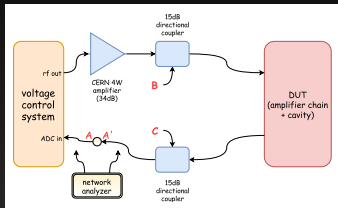

- set point: $(I, Q) = (0, 0)$
- FB closed
- phase offset LUT set
- gain LUT constant / set
- S_{21} from A to A' measured by NA
- **h1-h6 blocks used**, $f_{rf(h2)} = 1.2$ MHz, S_{21} (A to A') is measured by network analyzer
 - Gain LUT constant: gain is different for each harmonic
 - Gain LUT set: similar response for all harmonics
- Phase is near 180 deg at the centers of harmonics
 - condition to close FB

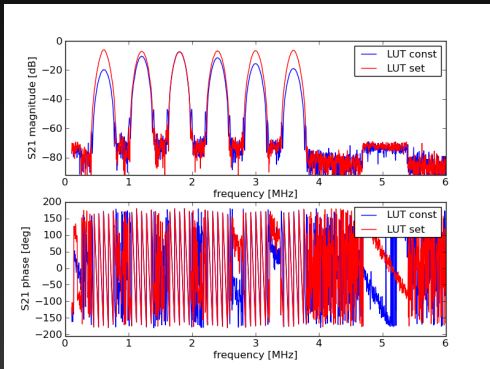

Now, we are ready to close the feedback.

Measurement of closed loop gain

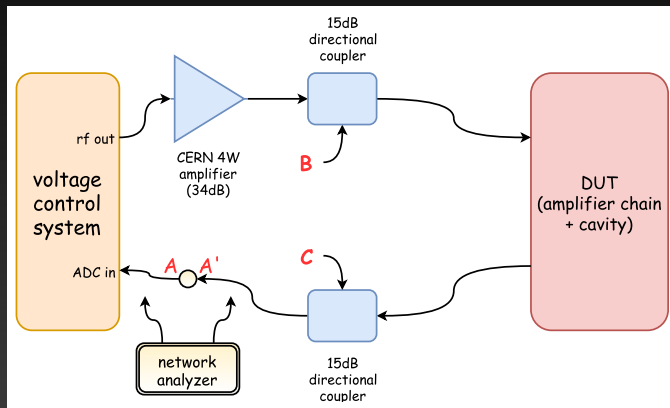

- I/Q pattern=0, FB closed, S_{21} from B to C measured
 - rf signal from NA is disturbance for the FB

Closed loop gain, LUT const vs set

$f_{rf} = 1.7 \text{ MHz}$ (near f_{res}), with various PI gain

Gain LUT constant

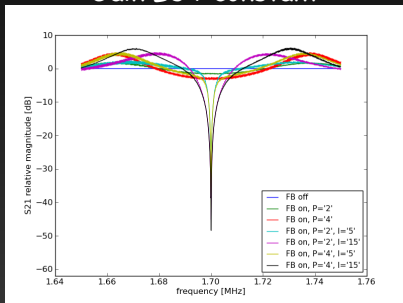

Gain LUT set

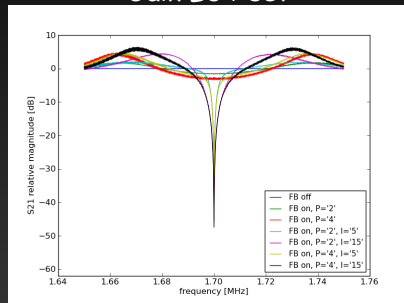

- With I gain, FB gain better than 30 dB achieved
 - Narrow BW ($\Delta f = 1 \text{ kHz}$, several dB)
- No difference between LUT const and set

Closed loop gain, LUT const vs set

$f_{rf} = 5.1$ MHz, with various PI gain

Gain LUT constant

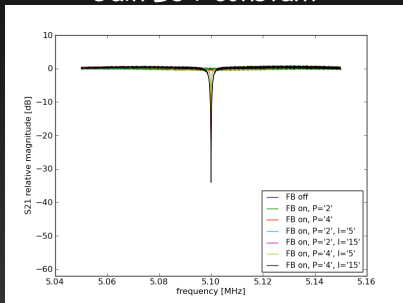

Gain LUT set

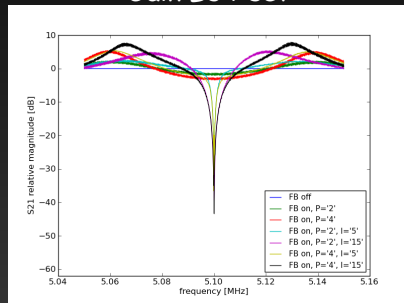

- Gain LUT constant: FB is not good because system gain is small at high frequencies
- With gain LUT set, similar response to 1.7 MHz obtained

Closed loop gain, LUT const vs set

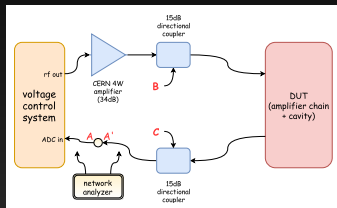

- set point: $(I, Q) = (0, 0)$
- FB closed
- phase offset LUT set
- gain LUT constant / set
- S21 from B to C measured by NA
- P, I gain set
- **h1-h6 blocks used**, $f_{rf(h2)} = 1.2$ MHz
 - Gain LUT constant: FB response is different for each harmonic
 - Gain LUT set: similar response for all harmonics

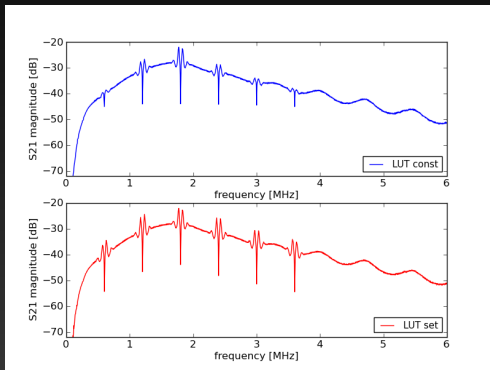

Multiharmonic FB is established.

Closed loop gain, LUT const vs set

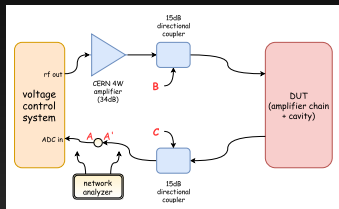

- set point: $(I, Q) = (0, 0)$
- FB closed
- phase offset LUT set
- gain LUT constant / set
- S21 from B to C measured by NA
- P, I gain set
- **h1-h6 blocks used**, $f_{rf(h2)} = 1.2$ MHz
 - Gain LUT constant: FB response is different for each harmonic
 - Gain LUT set: similar response for all harmonics

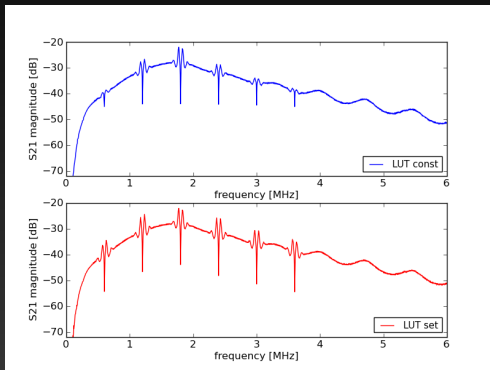

Multiharmonic FB is established.

Reduction of distortion

Voltage waveform distortion is an issue with combination of tube amplifier and wideband cavity. Multiharmonic FB can suppress the distortion.

Voltage pattern h2 only, $f_{rf} = 0.8$ MHz, higher harmonic FB OFF/ON

Harmonic components

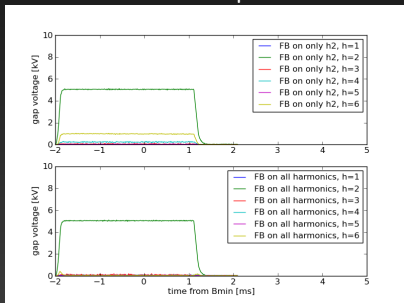

Voltage waveform

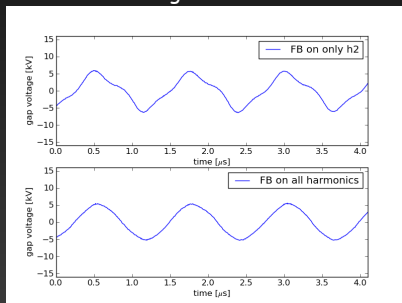

- Higher harmonic components / waveform distortion reduced, close to sinusoidal
- It is important to reduce distortion for comparison between beam simulation and real beam
 - distortion is hardly included in particle simulation codes

1. Introduction

2. Multiharmonic vector voltage control system prototype

3. Commissioning

4. Beam test results

5. Summary and outlook

Demonstration of wake voltage suppression

Gap voltage is measured without driving rf while other cavities generates rf voltages. Beam intensity: 4.3×10^{13} ppp (510 kW-eq). set point: (I, Q) = (0, 0).

Harmonic components

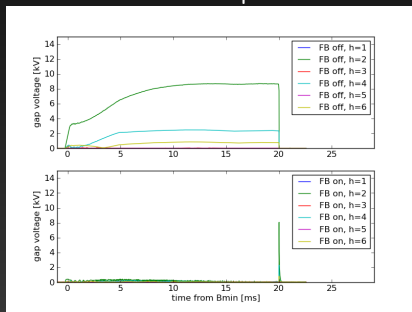

Voltage waveform at 19.9 ms

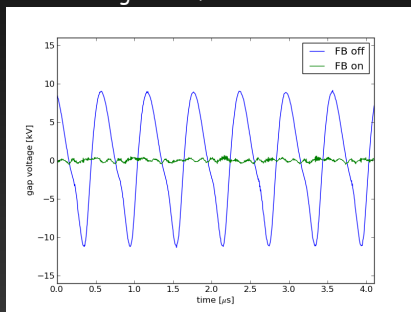

- **FB OFF (top):** Gap voltage consists only of wake
 - h2, h4, h6: max 8 kV, 2.5 kV, 0.9 kV
 - 2 bunch acceleration \rightarrow no odd harmonics
- **FB ON (bottom):** wake voltage is suppressed
 - h2, h4, h6: max 0.4 kV, 0.2 kV, 0.1 kV

- **FB OFF (blue):** voltage waveform is superposition of the wake harmonics.
Large amplitude, ~ 10 kV
- **FB ON (green):** wake is nicely suppressed, less than 1 kV

Demonstration of wake voltage suppression

Single bunch acceleration:

Harmonic components

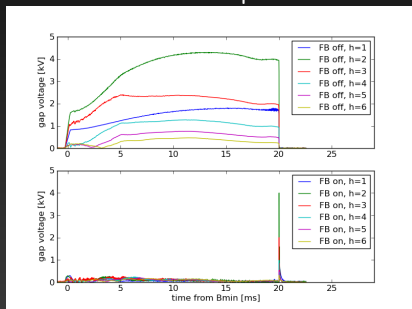

Voltage waveform at 19.9 ms

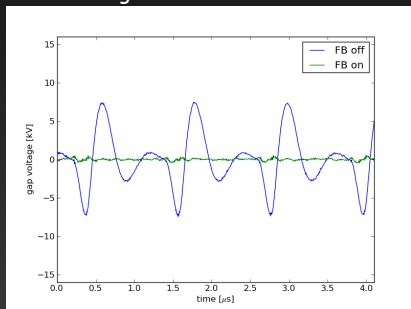

- In case of single bunch acceleration at 2.18×10^{13} ppp (260 kW-eq), **odd harmonics seen**
- Also suppression is good

Beam loading compensation with generating rf voltage

Realistic situation:

- Wake cannot be measured directly with generating rf voltage
- Following measurements performed:
 - For driving harmonics h2, h4:
amplitude and phase compared to no beam case
 - For other harmonics without driving (h1, h3, h5, h6, and h4 after 5 ms):
just check amplitudes are suppressed
- Similar voltage to the existing LLRF is generated by vector voltage control

7.7×10^{13} ppp, 920 kW-eq, very high power beam used.

Beam loading compensation with generating rf voltage

Comparison of amplitude and phase of driving harmonics (h2, h4), without and with high intensity beam (920 kW-eq).

- Blue: no beam
- green: 920 kW-eq beam

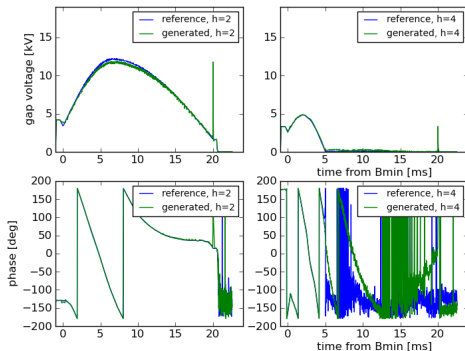

- Phase: very close to no beam for h2, h4
- Amplitude: h2 shows max 3% error near the voltage peak (5-12 ms), while h4 has almost no errors
 - Reason of error: saturation of driver amplifier is suspected

Beam loading compensation with generating rf voltage

Gain LUT constant:

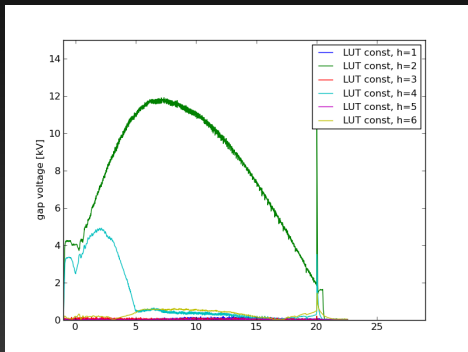

No odd harmonics because of two bunch acceleration.

- h4, h6 max 0.6 kV
- Distortion observed. Near extraction, effect enhanced
- Higher harmonics components not only wake but also tube current distortion

8 ms

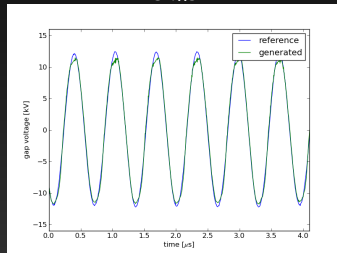

19.9 ms

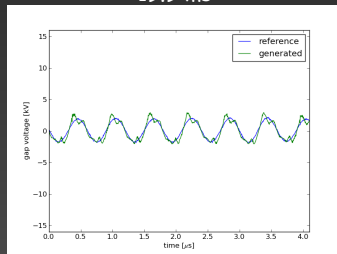

Beam loading compensation with generating rf voltage

Gain LUT set:

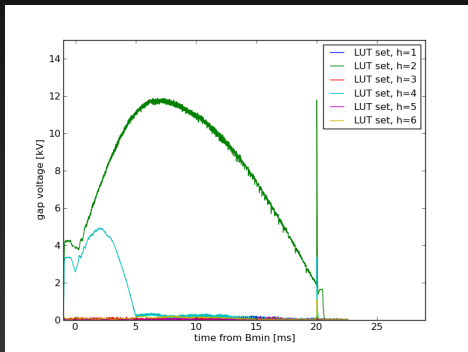

- h4, h6 max 0.3 kV
- Better suppression near extraction
- Distortion much reduced

The measurement demonstrates advantages of gain LUT setting.

8 ms

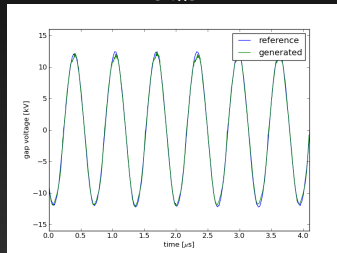

19.9 ms

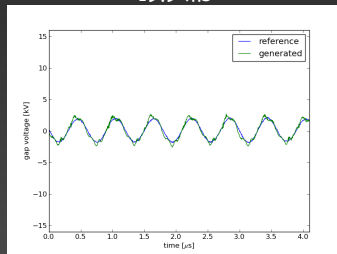

Beam loading compensation with generating rf voltage

Gain LUT set:

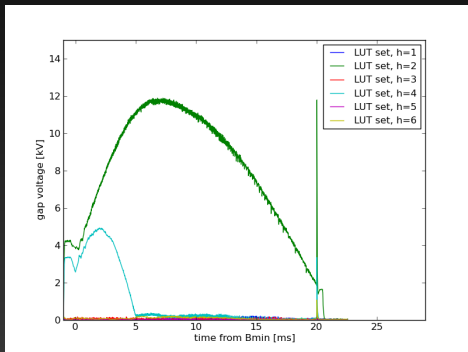

- h4, h6 max 0.3 kV
- Better suppression near extraction
- Distortion much reduced

The measurement demonstrates advantages of gain LUT setting.

8 ms

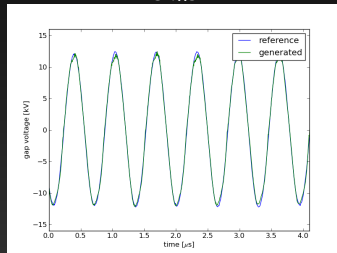

19.9 ms

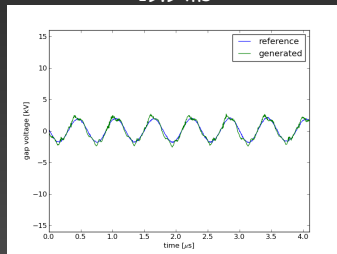

Summary and outlook

- A vector voltage control system prototype for J-PARC RCS has been developed
 - LUTs commissioned
 - High intensity beam test performed successfully
 - Consolidation of amplifier chain needed
- In FY2017-2018, next generation LLRF will be constructed (budget secured)
 - Other functions (phase FB etc.) also to be implemented

Backup slides

System transfer function

$$f_{\text{rf}(h2)} = 1.2 \text{ MHz}$$

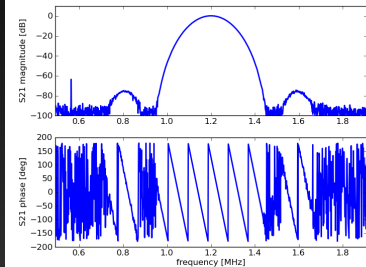

$$f_{\text{rf}(h2)} = 1.7 \text{ MHz}$$

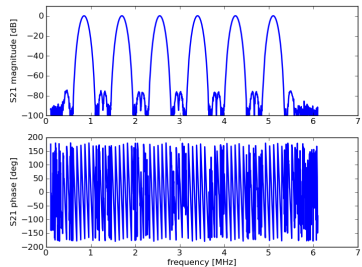
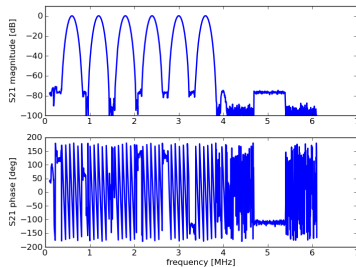
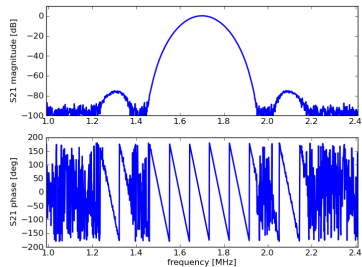

CIC filter (N=5, M=2, R=256) is used as LPF.

Closed loop gain

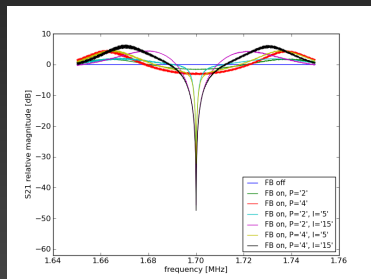
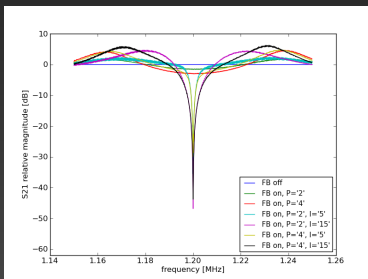
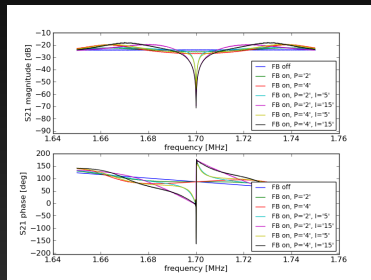
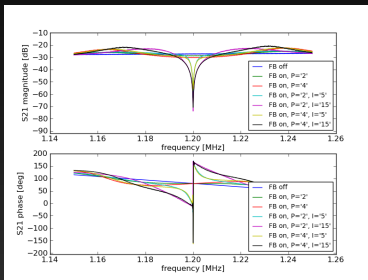

1.2, 1.7 MHz

Closed loop gain, LUT const vs set

1.7 MHz, LUT const vs LUT set

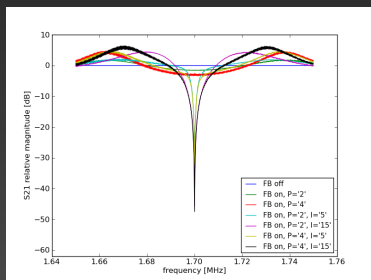
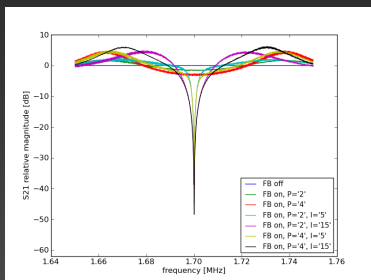
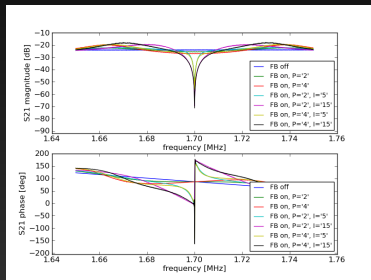
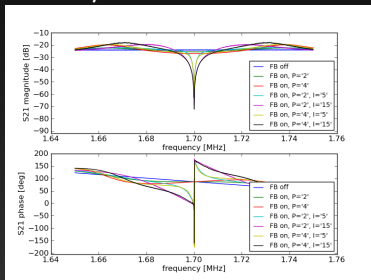

Closed loop gain, LUT const vs set

5.1 MHz, LUT const vs LUT set

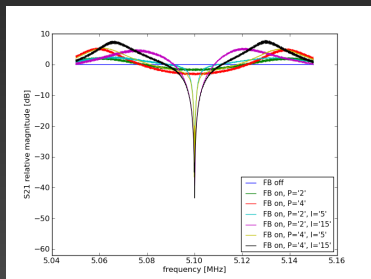
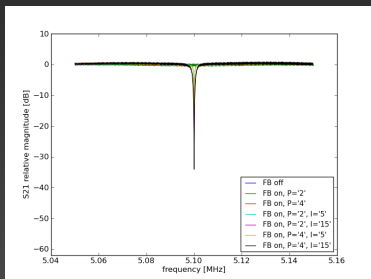
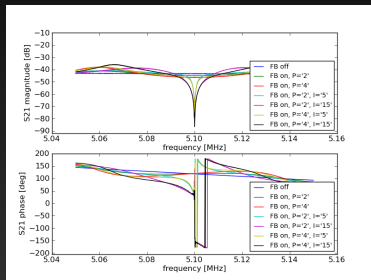
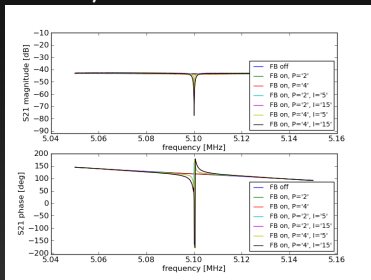

Phase pattern setting

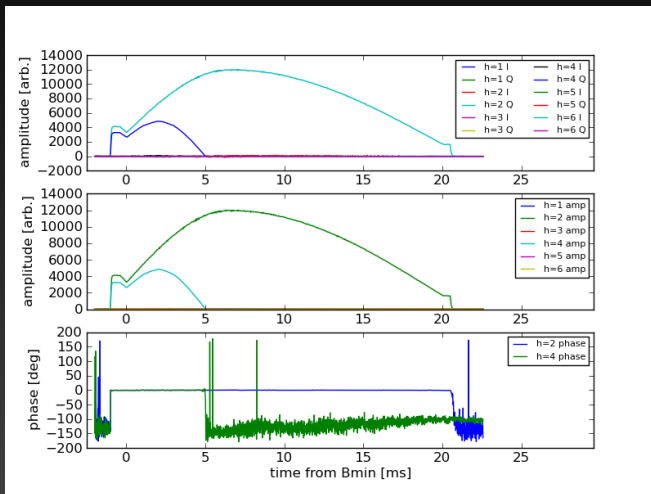

- Similar voltage envelop is easily generated by the system
 - I: amplitude pattern, Q: 0
- The phase is different from existing LLRF

Phase pattern setting

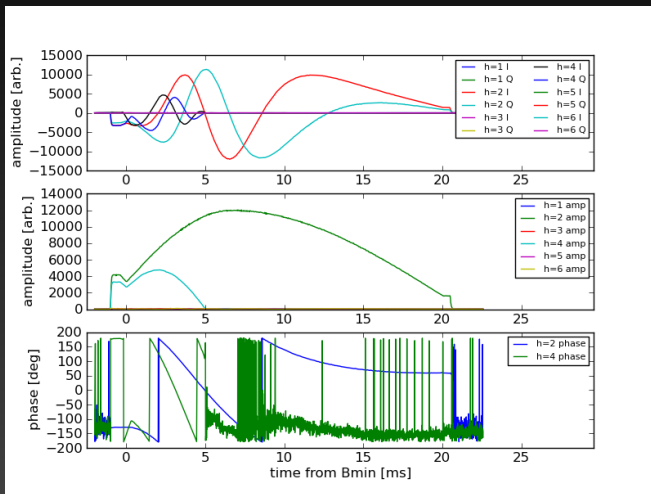

- From phase of voltage by existing LLRF, I/Q pattern generated

Phase pattern setting

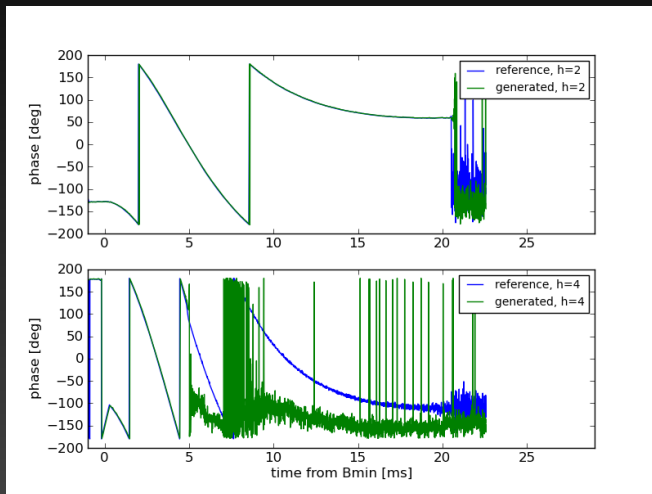

- within 1 deg from reference

7.7×10^{13} ppp, (920 kW-eq), LUT const

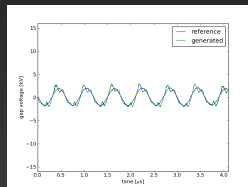
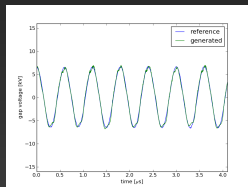
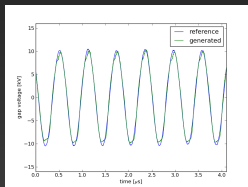
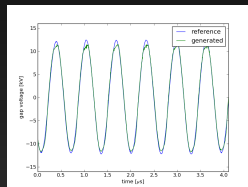
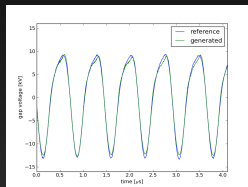
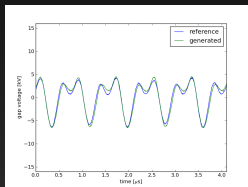

$\tau = 0, 4, 8, 12, 16, 19.9$ ms

7.7×10^{13} ppp, (920 kW-eq), LUT set

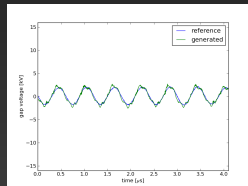
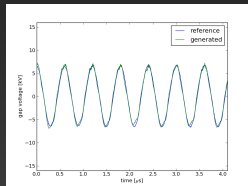
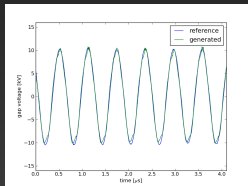
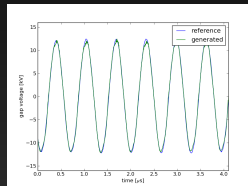
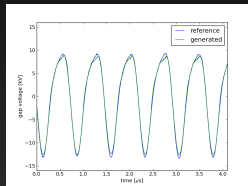
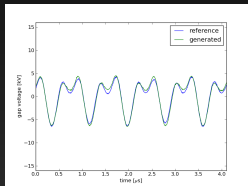

$\tau = 0, 4, 8, 12, 16, 19.9$ ms

7.7×10^{13} ppp, LLRF output, 10 ms

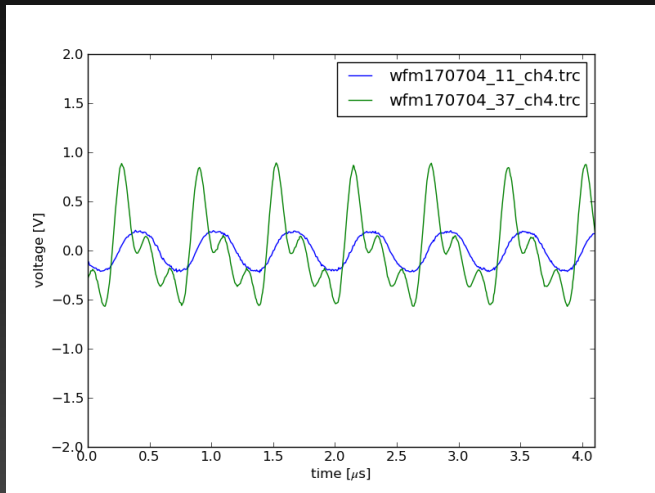

Comparison of waveforms w/o beam and w/ beam.

Comparison of suppression

Harmonic components of gap voltage, 7.7×10^{13} ppp, (920 kW-eq). No odd harmonics seen because two bunches accelerated.

- Top: feedforward (existing system)
- Middle: FB ON, gain LUT constant
- Bottom: FB ON, gain LUT set

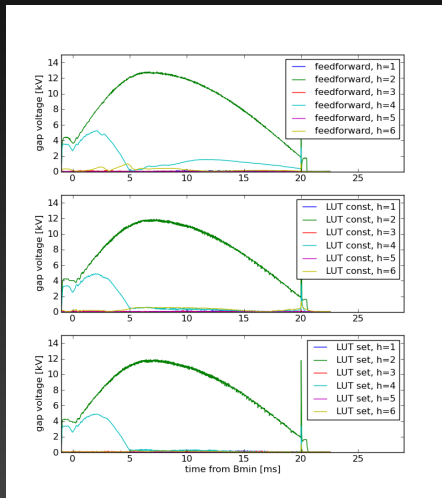

Odd harmonics compensation for high intensity beam

Motivation:

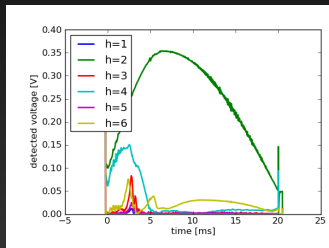
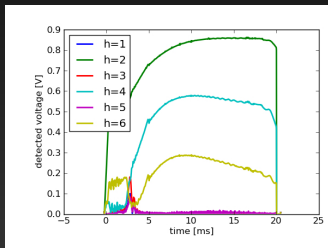

We want to compensate odd harmonics with high intensity beam

- single bunch acceleration \rightarrow only 450 kW
- Thinning "0xffffeee" \rightarrow particle population 16:12

Odd harmonics compensation for high intensity beam

Thinning 0xffffeee, 6.7e13 ppp, 800 kW-eq

- particle population 16:12

h135 FB off

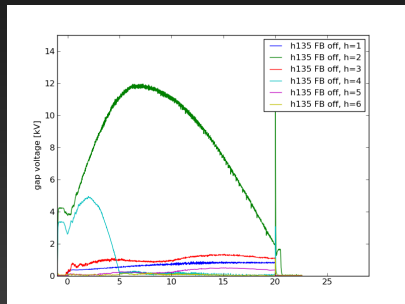

- h135 wake observed

All harmonic FB on

- Suppressed

Odd harmonics compensation for high intensity beam

Thinning 0xffffeee, 6.7e13 ppp, 800 kW-eq

- particle population 16:12

h135 FB off

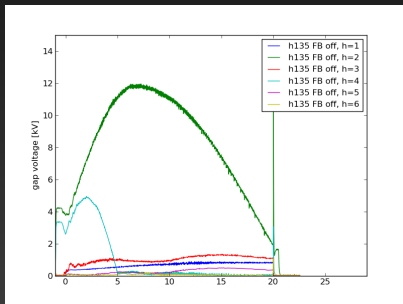

- h135 wake observed

All harmonic FB on

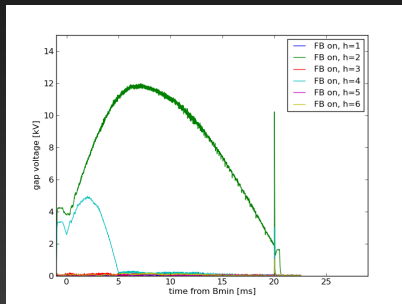

- Suppressed